

Short Case Series – SCD404

Location

Project



Designation

Notes

Features

The Short Case Axial Series of fans is designed for duct mounting. The fans are suitable for a wide range of applications.

Construction

Galvanised steel coated with polyester epoxy finish as standard. Impellers are of injection moulded glass-reinforced plastic. Aluminium blades are an optional extra.

Motors

Type - squirrel cage induction motor.
Electricity supply - 220-240V single or 415V three-phase, 50Hz.
Bearings - sealed-for-life ball.
Speed-controllable using electronic controllers or auto transformers.
Enclosure IP55.

Internal Thermal Protection

Manual reset protection is supplied as standard in these units.

Testing

Air flow tests to BS848:Part 1, 1980.
Noise tests BS848:Part 2, 1985.

Special Features

Can be mounted at any angle.
Can operate in ambients from -20°C up to 70°C, or maximum of 50°C when being speed controlled.
Most three-phase external rotor motors are 2-speed star/delta design.
An electrical junction box is fitted as standard.

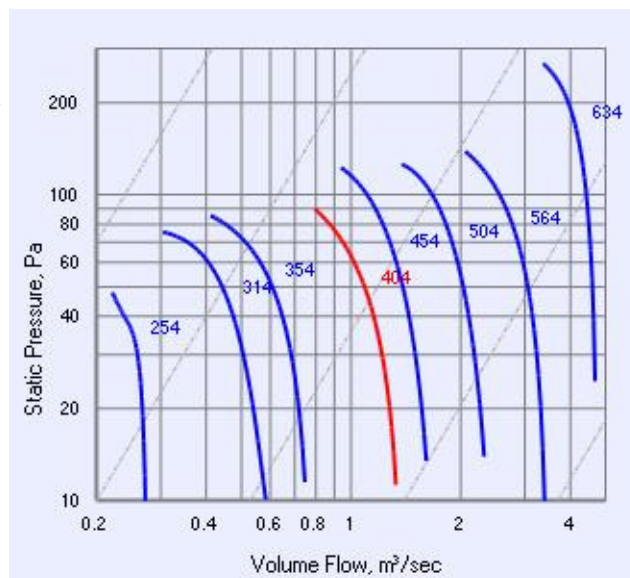

Technical Data - SCD404

Speed [rps]	Avg. dBA @ 3m	kWatts (Input)	Amps	Max.° C	Approx. Weight [kg]
22	47	0.37	1.4	40	12

Sound Data

Type	63	125	250	500	1K	2K	4K	8K
Inlet	69	68	65	64	64	60	56	50

Short Case Series – SCD404

Suggested Specification

The Short Case Axial Series of fans shall be as supplied by Fantech Pty Ltd. The axial impellers shall be of GRP and driven by single-phase speed-controllable or three phase motors with integral thermal protection.

Cases shall be of galvanised construction with a polyester epoxy finish.

All models shall be fully tested to BS848:Part 1, 1980 for air flow and to BS848:Part 2, 1985 for noise.

Dimensions

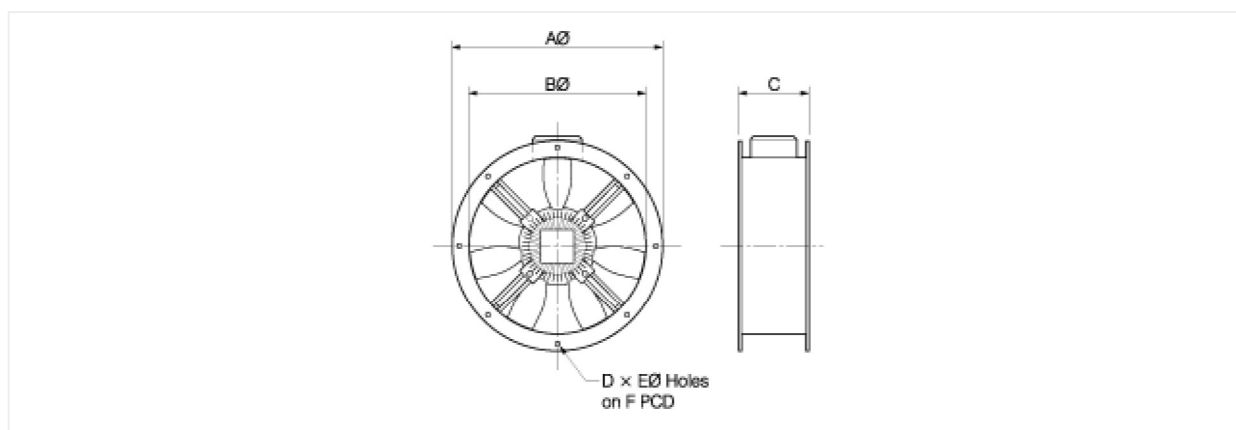

A	B	C	D	E	F
466	400	190	12	9.5	438

All dimensions in mm, unless otherwise stated

Contacts



OFFICES & AGENTS

Victoria

Fantech Pty. Ltd.
Tel:+61 (03) 9554-7845

New South Wales

Fantech Pty. Ltd.
Tel:+61 (02) 8811-0400

Uniair Distributors Pty. Ltd.

Tel:+61 (02) 4961-6088
Refrigeration and Air Supplies
Tel:+61 (02) 4226-5133
Fantech Pty. Ltd.
Tel:+61 (02) 6025-1866

South Australia

Fantech Pty. Ltd.
Tel:+61 (08) 8294-0530

Queensland

Air Design Pty. Ltd.
Tel:+61 (07) 3299-9888
Capricorn Air Conditioning
Tel:+61 (07) 4775-5222

Northern Territory

Fantech Pty. Ltd.
Tel:+61 (08) 8947-0447

Western Australia

Systemaire Pty. Ltd.
Tel:+61 (08) 9209-4999

Tasmania

Major Air Pty. Ltd.
Tel:+61 (03) 6344-6888
Hobart
Tel:+61 (03) 62736455

ACT

Idealair Group Pty. Ltd.
Tel:+61 (02) 6280-5511

Auckland

Fantech (NZ) Ltd.
Tel:+64 (09) 444-6266

Christchurch

Fantech (NZ) Ltd.
Tel:+64 (03) 379-8622

Wellington

Fantech (NZ) Ltd.
Tel:+64 (04) 566-0532