

Biax™ S and S/E

Compact Fluorescent Lamps Non-Integrated 5W, 7W, 9W and 11W

Product information

Biax™ S compact fluorescent lamps can provide savings of up to 73% in energy costs compared to incandescent lamps. Available in 5, 7, 9 and 11 watt ratings, low wattage Biax™ S lamps are ideal for new installations or to replace existing incandescent lamps. These lamps are available in 2700, 3000, 3500, 4000 and 6500K colour temperatures. The Biax™ S lamps have built-in internal starters. They have a rated average life of 10,000 hours, which results in fewer lamp changes and a reduction in maintenance costs over the life of an installation. The Biax™ S/E lamps are available in 5, 7, 9 and 11 watt ratings. However, the Biax™ S/E lamps have 4-pin caps without built-in capacitors and starters, they are therefore suitable for operation with electronic control gear and can be used for dimming and emergency lighting applications. Biax™ S/E lamps have the same energy saving benefits and high quality colour rendering as the Biax™ S range.

The use of separate electronic ballasts makes them suitable for almost every kind of energy supply: high and low voltages, accumulators, batteries, solar cells and systems that can be dimmed.

When the new fluorescent lamp is installed into dimming system, it is advised to operate lamps for period of 100 hours at full light output.

Features

- Flat and compact
- High luminous efficacy
- Up to 73% energy-saving compared to incandescent lamps
- 10 times the lamp life of incandescent lamps
- Pleasant light, excellent colour rendering.

Application areas

- Wall & ceiling luminaires
- In hotels, motels, office buildings, apartments
- Building, public areas
- Ideal for task light applications also
- Emergency lighting
- Enclosed outdoor fixtures



Basic data

Nominal Wattage [W]	Rated Power [W]	Energy consumption [kWh/1000h]	Volts [V]	Cap	Product Description	Product Code	Nominal Lumen [lm]	Rated Lumen [lm]	Rated Lamp Efficacy [lm/W]	CCT [K]	CRI [Ra]	Mercury [mg]	Life on 3h Standard Gear [h]	Diameter [mm]	Length [mm]	EEC	Pack Qty
Biax™ S 2-pin, Internal Starter																	
5	5.4	7.15	35	G23	F5BX/SPX27/827	37654	265	265	49	2700	82	1.3	10,000	32	107.5	B	10
5	5.4	7.15	35	G23	F5BX/SPX41/840	37661	265	265	49	4000	82	1.3	10,000	32	107.5	B	10
7	7.1	9.18	47	G23	F7BX/SPX27/827	37846	425	425	60	2700	82	1.3	10,000	32	136.5	A	10
7	7.1	9.18	47	G23	F7BX/830	38930	425	425	60	3000	82	1.3	10,000	32	136.5	A	10
7	7.1	9.18	47	G23	F7BX/SPX35/835	37659	425	425	60	3500	82	1.3	10,000	32	136.5	A	10
7	7.1	9.18	47	G23	F7BX/SPX41/840	37660	425	425	60	4000	82	1.3	10,000	32	136.5	A	10
7	7.1	9.18	47	G23	F7BX/865	38984	425	425	60	6500	82	1.3	10,000	32	136.5	A	10
9	8.7	11.05	60	G23	F9BX/827	37651	600	600	69	2700	82	1.3	10,000	32	167	A	10
9	8.7	11.05	60	G23	F9BX/830	38929	600	600	69	3000	82	1.3	10,000	32	167	A	10
9	8.7	11.05	60	G23	F9BX/SPX35/835	37652	600	600	69	3500	82	1.3	10,000	32	167	A	10
9	8.7	11.05	60	G23	F9BX/SPX41/840	37653	600	600	69	4000	82	1.3	10,000	32	167	A	10
9	8.7	11.05	60	G23	F9BX/865	38985	600	600	69	6500	82	1.3	10,000	32	167	A	10
11	11.8	14.69	91	G23	F11BX/827	37663	900	900	76	2700	82	1.3	10,000	32	237	A	10
11	11.8	14.69	91	G23	F11BX/830	38928	900	900	76	3000	82	1.3	10,000	32	237	A	10
11	11.8	14.69	91	G23	F11BX/835	37666	900	900	76	3500	82	1.3	10,000	32	237	A	10
11	11.8	14.69	91	G23	F11BX/840	37664	900	900	76	4000	82	1.3	10,000	32	237	A	10
11	11.8	14.69	91	G23	F11BX/840	38986	900	900	76	6500	82	1.3	10,000	32	237	A	10

Nominal Wattage [W]	Rated Power [W]	Energy consumption [kWh/1000h]	Volts [V]	Cap	Product Description	Product Code	Nominal Lumen [lm]	Rated Lumen [lm]	Rated Lamp Efficacy [lm/W]	CCT [K]	CRI [Ra]	Mercury [mg]	Life on electronic gear 12h cycle (h)	Diameter [mm]	Length [mm]	EEC	Pack Qty
Biax™ S/E 4-pin, External Starter Required																	
5	5.4	5.50	35	2G7	F5BX/827/4P	37714	265	265	49	2700	82	1.3	15,000	37.5	92	A	10
5	5.4	5.50	35	2G7	F5BX/840/4P	37715	265	265	49	4000	82	1.3	15,000	37.5	92	A	10
7	7.1	7.15	47	2G7	F7BX/827/4P	37658	425	425	60	2700	82	1.3	15,000	37.5	121	A	10
7	7.1	7.15	47	2G7	F7BX/840/4P	37716	425	425	60	4000	82	1.3	15,000	37.5	121	A	10
9	8.7	8.80	60	2G7	F9BX/827/4P	37710	600	600	69	2700	82	1.3	15,000	37.5	151	A+	10
9	8.7	8.80	60	2G7	F9BX/840/4P	37711	600	600	69	4000	82	1.3	15,000	37.5	151	A+	10
11	11.8	12.10	91	2G7	F11BX/827/4P	37717	900	900	76	2700	82	1.3	15,000	37.5	222	A+	10
11	11.8	12.10	91	2G7	F11BX/840/4P	37713	900	900	76	4000	82	1.3	15,000	37.5	222	A+	10
11	11.8	12.10	91	2G7	F11BX/865/4P	12603	900	900	76	6500	82	1.3	15,000	37.5	222	A+	10

Dimensions

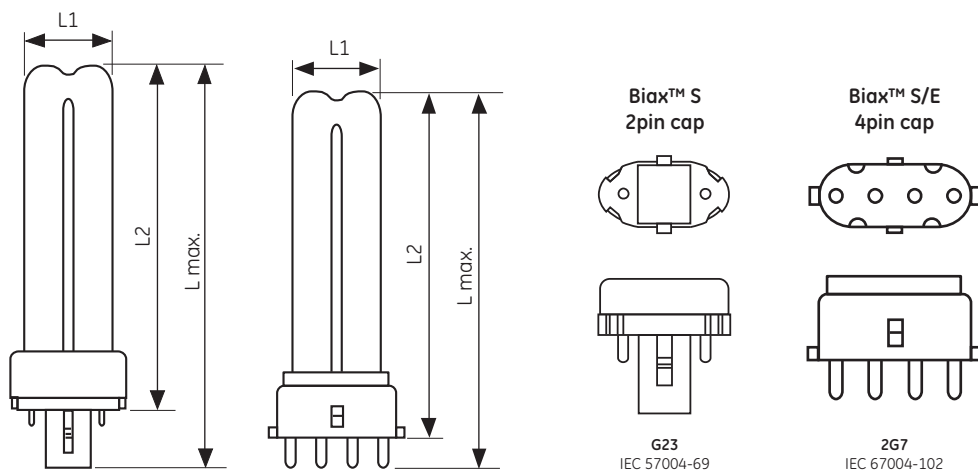

	L max [mm]	L1 [mm]	L2 [mm]
Biax™ S			
5W	107.5	27	85
7W	136.5	27	114
9W	167	27	144.5
11W	237	27	214.5
Biax™ S/E			
5W	92	27	85
7W	121	27	114
9W	151	27	144
11W	222	27	215

Lamp life

Rated average life for Biax™ S & S/E lamps is 10,000 hours (switching cycle: 3 Hrs: 165Mins ON / 15Mins OFF).

Lumen maintenance

Lumen maintenance curve presented for Biax™ S & S/E lamps is based on lumen readings in a photometric sphere under laboratory conditions, in cap up position. In actual use, lumen output is a function of burning hours and lamp operating watts throughout life.

Survival rate and lumen maintenance

5 W and 7W

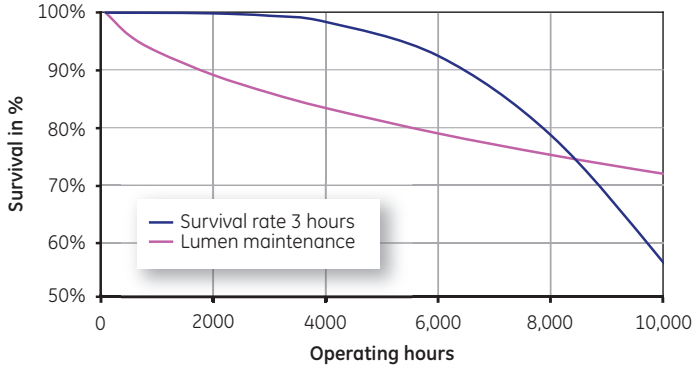

Survival rate and lumen maintenance

9W and 11W

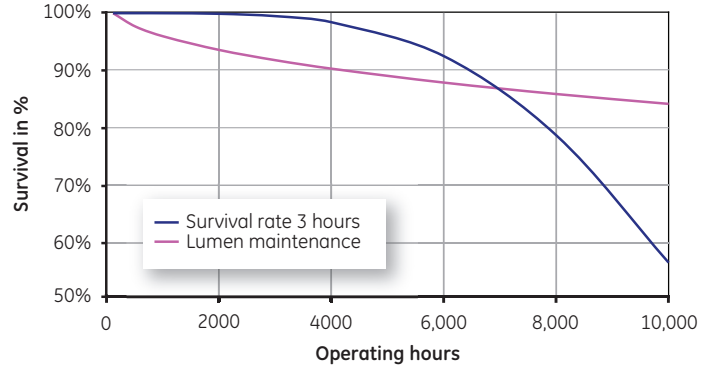

	Survival rate 3 hours	Lumen maintenance
100	1.00	1.00
2,000	1.00	0.89
4,000	0.98	0.83
6,000	0.92	0.79
8,000	0.78	0.75

	Survival rate 3 hours	Lumen maintenance
100	1.00	1.00
2,000	1.00	0.93
4,000	0.98	0.90
6,000	0.92	0.88
8,000	0.78	0.86

Effect of frequent switching

Lamps survive min. 20,000 switching cycles with appropriate electronic gear or external starter.

Effects of supply voltage variations on lamp performance

Biax™ S & S/E lamps are suitable for supplies in the range 200V to 240V, 50Hz for appropriately rated series choke (reactor) ballasts. Supplies outside this range require a transformer (conventional, high reactance or CWA) to ensure correct lamp operation. Lamps start and operate at 10% below the rated supply voltage when the correct control gear is used. However, in order to maximise lamp survival, lumen maintenance and colour uniformity, the supply voltage and ballast design voltage should be within $\pm 3\%$. Supply variations of $\pm 5\%$ are permissible for short periods only. This may be achieved by measuring mean supply voltage at the installation and selecting ballasts with appropriate settings.

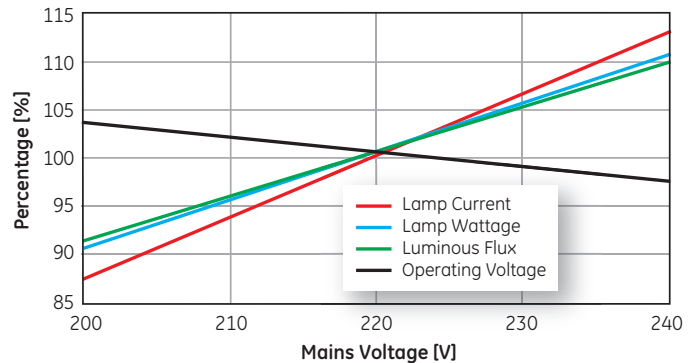

Luminous intensity distribution

The luminous intensity distribution curve shows the horizontal light intensity of Biax™ S & S/E lamps.

Radial luminous intensity distribution

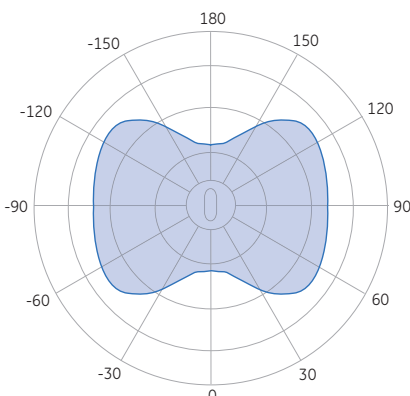

Effects of temperature changes

When installed in a luminaire, the temperature of the air surrounding the lamp cap changes and this can affect the light output of the lamp. The effects of changes in ambient temperature for a typical lamp are in the graph below.

Lumen output vs. ambient air temperature

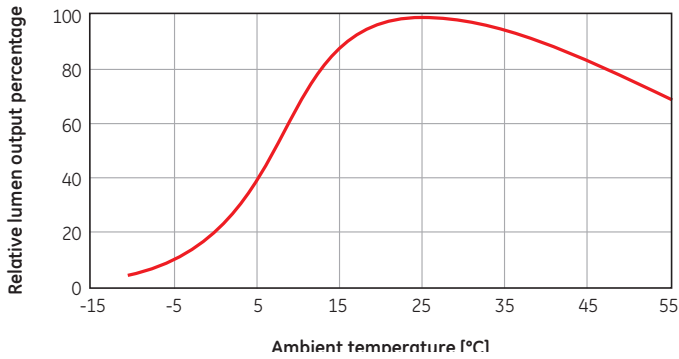

Spectral distribution

Spectral power distribution (2700K)

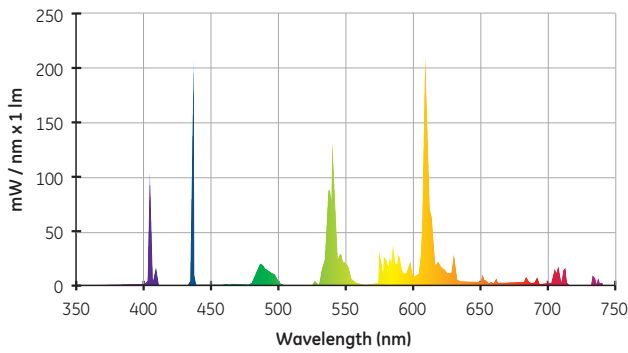

Spectral power distribution (3000K)

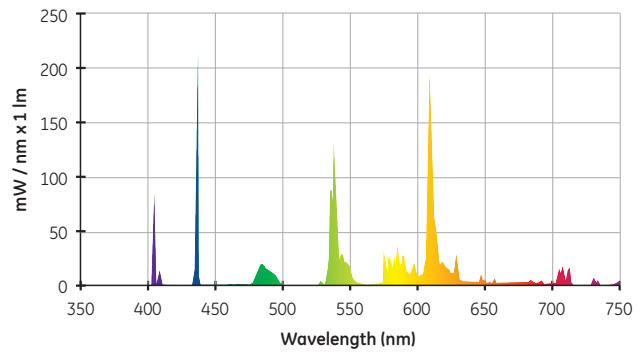

Spectral power distribution (3500K)

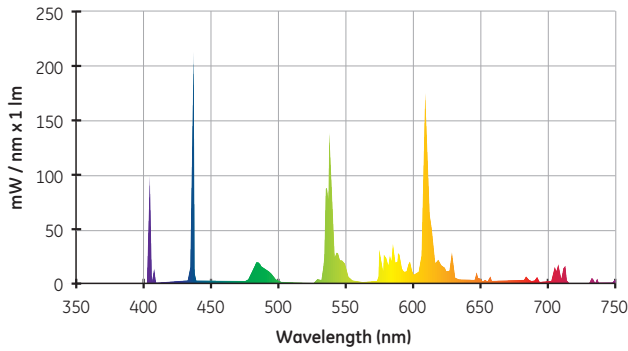

Spectral power distribution (4000K)

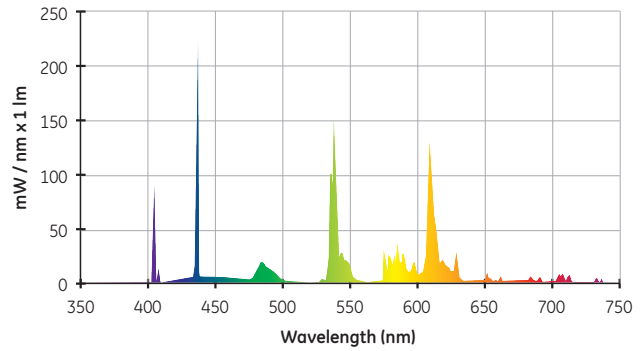

Spectral power distribution (6500K)

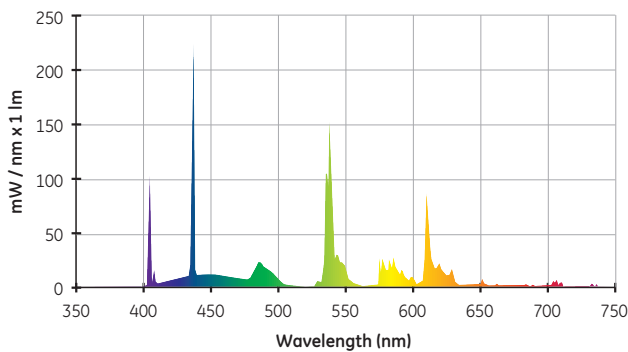

Circuit diagrams

Parallel compensated

B = ballast (50Hz)
LH = lamp holder

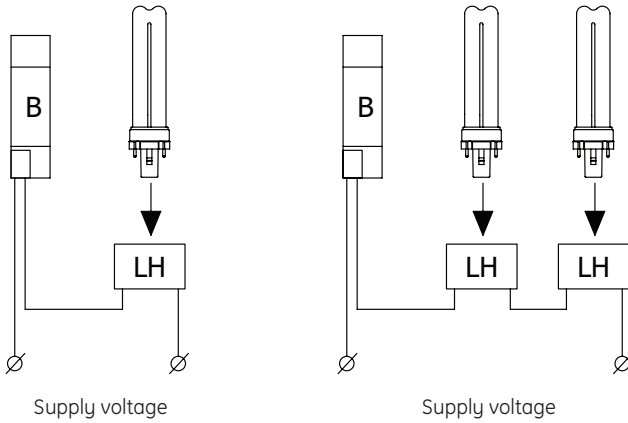

Biax™ S
5W, 7W, 9W and 11W

Parallel compensated

E = electronic gear
LH = lamp holder

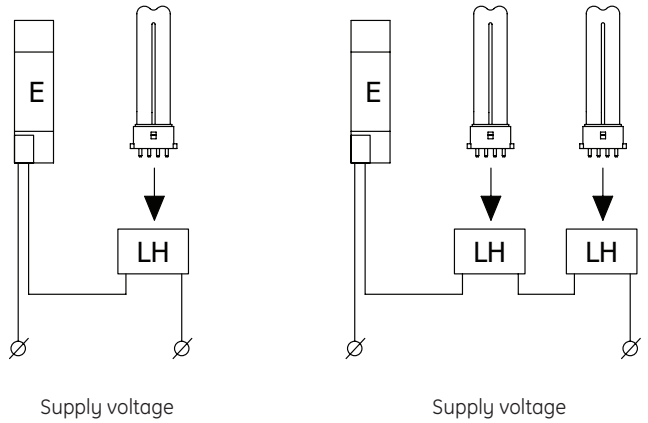

Biax™ S/E
5W, 7W, 9W and 11W

Recommended list of ballasts*

	Wattage	Lamp description	Ballast manufacturer	Single ballast description	Twin ballast description
Biax™ S/E 4-pin	5W	F5BX/827/4P	Tridonic Atco Vossloh-Schwabe	PC 1x5-16 W Basic ELXc.109.403	
Biax™ S/E 4-pin	7W	F7BX/827/4P	Tridonic Atco Hüco Vossloh-Schwabe	PC 1x5-16 W Basic EVG 1x7-13W HMC ELXc.109.403	
Biax™ S/E 4-pin	9W	F9BX/827/4P	Tridonic Atco Helvar Hüco Vossloh-Schwabe	PC 1x5-16 W Basic EL 1/2x9-13TCs EVG-HP 1x/2x9-21W HC ELXc.109.403	PC 2/9/11 TCS PRO EL 1/2x9-13TCs EVG-HP 1x/2x9-21W HC
Biax™ S/E 4-pin	11W	F11BX/827/4P	Tridonic Atco Helvar Hüco Vossloh-Schwabe	PC 1/9/11 TCS PRO EL 1/2x9-13TCs EVG-HP 1x/2x9-21W HC ELXc.113.402	PC 2/9/11 TCS PRO EL 1/2x9-13TCs EVG-HP 1x/2x9-21W HC

*Ballast manufacturers have the right to change ballast specification without prior notification or official announcement so these data based on GE measurement 2010/2011.

Compliance

Standards

IEC 60061-1	Lamp caps and holders together with gauges for the control of interchangeability and safety
IEC or EN 60901	Single-capped lamps - performance requirements
IEC or EN 61199	Single-capped lamps - safety requirements
CIE S 009/E:2002	Photobiological safety of lamps and lamp systems

European Directives

CE mark	93/68/EEC; LVD: 2006/95/EC; Ecodesign 2005/32/EC, ROHS 2011/65/EU
Energy Labelling	Directive 2010/30/EU, 874/2012/EU energy labelling of electrical lamps and luminaires
RoHS	Directive 2011/65/EU on Restrictions of the use of certain Hazardous Substances (RoHS)
WEEE	Directive 2012/19/EU on Waste Electrical and Electronic Equipment (WEEE)
REACH	Directive 2006/1907/EC on Registration, Evaluation, Authorisation and Restriction of Chemicals (REACH)
ErP ecodesign	Directive 2005/32/EC, 2009/245/EC ecodesign requirements (of Energy-related Products) for tertiary sector lamps
