

# Data Sheet



## Excel Life™ Medical Range Common Plate, Single Powerpoint, Antimicrobial\*, 10A marked "RCD PROTECTED"

Cat No. **EC787CAWE, EC787CABU, EC787CABE, EC787CARD**



<b>Cat No.</b>	<b>EC787CAWE, EC787CABU, EC787CABE, EC787CARD</b>
<b>Description</b>	Excel Life Common Plate, Single Powerpoint, Antimicrobial, 10A
<b>Supply voltage</b>	230 - 240V a.c.
<b>Current rating</b>	10A
<b>Colour</b>	White (WE), Blue (BU), Beige (BE), Red (RD)
<b>Dimensions (WxHxD)</b>	118 x 74 x 10mm
<b>Mounting centres</b>	84mm
<b>Compliance</b>	AS/NZS 3112

# Excel Life™ Medical Range Common Plate, Single Powerpoint, Antimicrobial\*, 10A marked "RCD PROTECTED"



Cat No. **EC787CAWE, EC787CABU, EC787CABE, EC787CARD**



- Inline terminals for easier installation
- Internal safety shutters for extra safety
- More fixing options - 4 corners
- Captive terminal screws
- Uniform external surround - fits all switches and powerpoints in the Common Plate series

*Antimicrobial Specifications			
<b>Maintenance</b>	Surface cleaning with cloth: Hospital-grade water-based cleaners only. Do not use any solvent based cleaner such as acetone, tar-remover or trichloroethylene.		
<b>Antimicrobial Properties</b>	Challenge Organism	Polycarbonate alloy in facia parts	Polycarbonate alloy in switch dolly
		Reduction Coefficient/Kill Rate	
<b>Note:</b> 5 Log = 99.9999% 4 Log = 99.99% 3 Log = 99.9% 2 Log = 99%	<b>Escherichia Coli</b>	2.55 Log / 99.72%	6.72 Log / 99.9999%
	<b>Staphylococcus aureus</b>	2.70 Log / 99.79%	5.22 Log / 99.9999%
	Tests performed according to JIS Z 2801:2010 (Antimicrobial products – Test for antimicrobial activity and efficacy). Test method is equivalent to procedure detailed in ISO 22196:2011 (Measurement of antibacterial activity on plastics and other non-porous surfaces). Test results available upon request. Not to be used as an alternative or substitute for standard hygienic practices, procedures, or protocols. This device has a long-term antimicrobial effect. Lifespan is dependent upon cleaning procedures and the use of recommended cleaning products. Product manufactured with antimicrobial material based on Ag+ ions. This technology limits the proliferation of bacteria on our devices without increasing antibiotic resistance.		

## Cut-out dimensions:



Single product	
Cat No.	Barcode
EC787CAWE	9321001428299
EC787CAWE	9321001442462
EC787CAWE	9321001428091
EC787CAWE	9321001427865

Inner box (Qty 10)		
Cat No.	Barcode	Dimensions (WxHxD)
EC787CAWE	9321001429104	160 x 160 x 120mm
EC787CABU	9321001443216	160 x 160 x 120mm
EC787CABE	9321001428909	160 x 160 x 120mm
EC787CARD	9321001428671	160 x 160 x 120mm

Outer box (Qty 120)		
Cat No.	Barcode	Dimensions (WxHxD)
EC787CAWE	9321001429883	500 x 333 x 266mm
EC787CABU	9321001443933	500 x 333 x 266mm
EC787CABE	9321001429715	500 x 333 x 266mm
EC787CARD	9321001429487	500 x 333 x 266mm

## Timber cut-out dimensions:

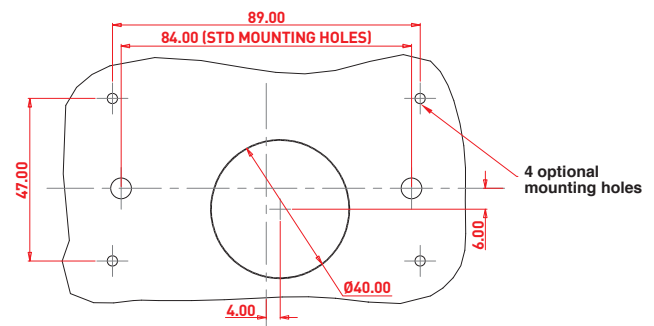

Legrand - Australia  
1300 369 777  
www.legrand.com.au  
ABN 31 000 102 661

Legrand - New Zealand  
0800 476 009  
www.legrand.co.nz

Refer to your group buying office, Legrand Sales Representative or Legrand Sales Office for pricing.

\* Specifications may change without notice