

Data Sheet

LED Satellite – Corridor



CAT NO. 659011LI, 659012LI



No trim





Small round trim



Medium round trim



Square trim

Specifications		
Cat No	659011LI	659012LI
Finish	White	Black
Battery pack	Li-ion 6.4V, 3.0Ah	
Operating Voltage	240V a.c. +/- 6% 50Hz	
Power Consumption	2W	
Body Constructions	Polycarbonate	
Operating Temperature	10° to 40°	
IP Rating	IP20	
Compliance	AS/NZS 2293 AS/NZS 60598  	



LED Satellite – Corridor

CAT NO. 659011LI, 659012LI



- Embedded Bluetooth for smart device connectivity
- Low Power Wide Area Network type of communications utilising the LoRaWAN platform
- LoRaWAN communication to maximise reliability, coverage and infiltration
- iSmart™ temperature sensing technology for the LIION battery
- Electronics designed to lengthen the life of the battery, minimising maintenance costs
- Environmentally friendly battery
- Easy to install
- Suitable for different hole sizes
- One high Brightness LED
- 5 year warranty
- Designed and manufactured in Australia

Cat No	Description	Classification C ₀ /C ₉₀
Galaxy		
659011LI	Galaxy LED Satellite Flex and Plug White	D80/E16
659012LI	Galaxy LED Satellite Flex and Plug Black	D80/E16

Trim	Dimensions	Hole cut-out
No Trim	56mmØ	52mmØ
Small ring	80mmØ	52mm - 60mmØ
Medium ring	120mmØ	52mm - 85mmØ
Medium square	120 x 120mm	52mm - 85mmØ

Spacing table:

Maximum spacings between luminaires as per AS/NZS 2293

Mounting Height (m)	2.4	2.7	3	3.3	3.6	4.0
A	22.0	22.8	23.6	24.3	25.0	25.8
B	9.2	9.8	10.6	11.0	11.6	12.2

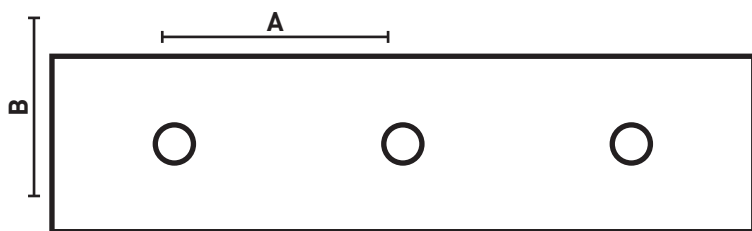

LED Satellite – Corridor



CAT NO. 659011LI, 659012LI



DIMENSIONS

Fascia

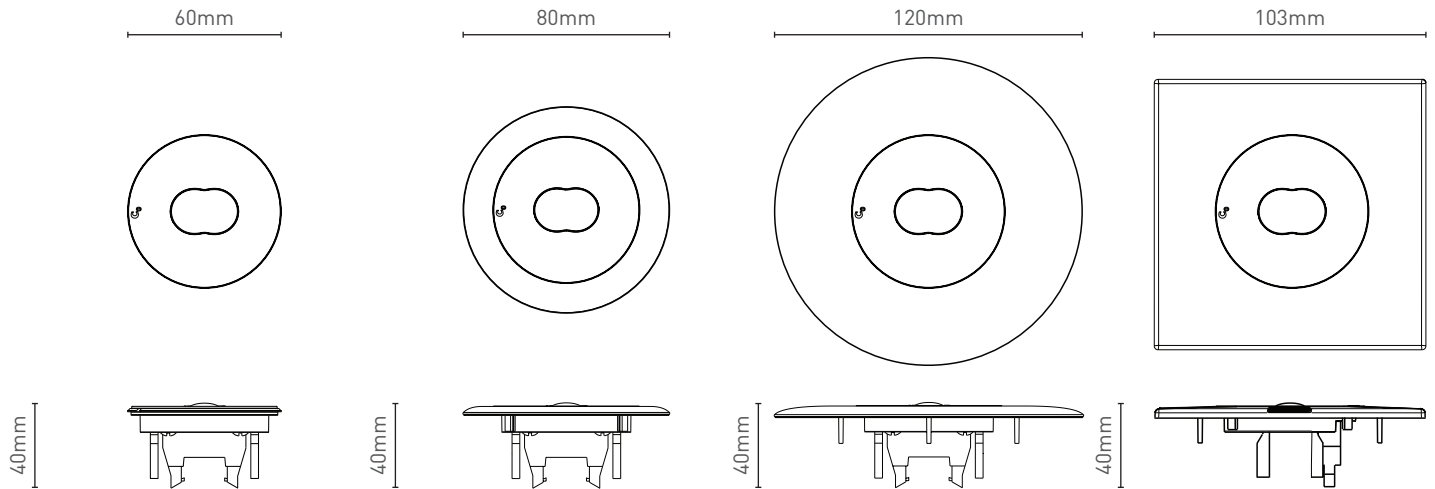

Power Pack

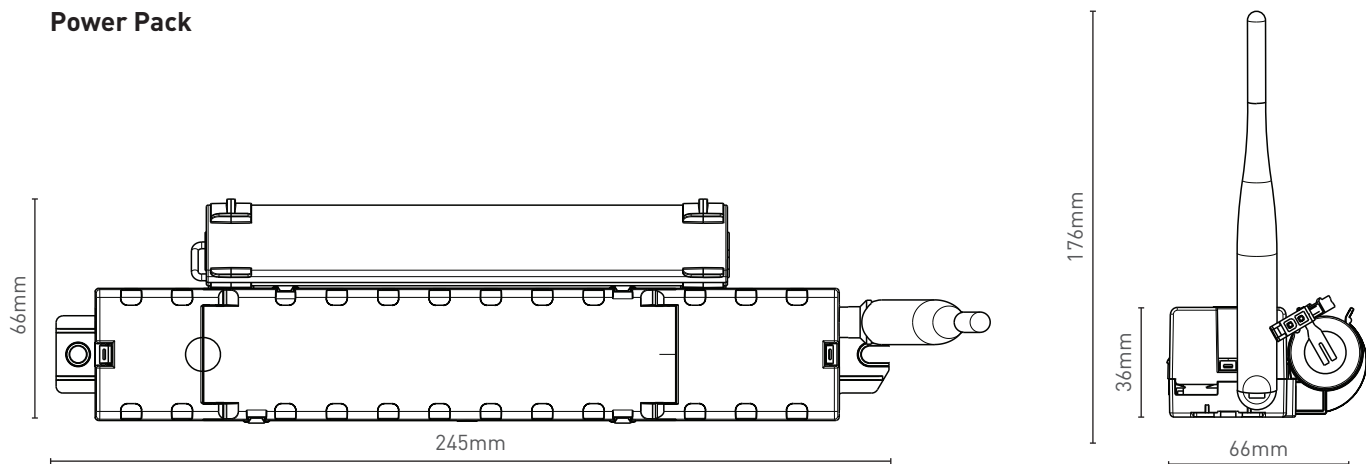

Legrand - Australia
1300 369 777
www.legrand.com.au
ABN 31 000 102 661

Legrand - New Zealand
0800 476 009
www.legrand.co.nz

Refer to your group buying office, Legrand Sales Representative or Legrand Sales Office for pricing.

Please note: specifications are subject to change without prior notice.