

atom'air

INSTALLATION SHEET

AC CEILING FAN

COOLUM/LT

4 blade 75W AC ceiling fan with LED light - Tri-colour

Dimensions

COOLUM/48/LT

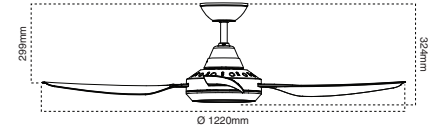

COOLUM/52/LT

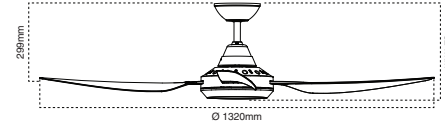

Product specification

Voltage	220-240V ~ 50Hz	
Power consumption	75W	
Electrical classification	I	
Motor	Ø172x20mm AC motor	
IP rating	IP20	
Blades	4	
Blade pitch	13.5°	
Airflow	COOLUM/48	13,800m³/hr (high)
	COOLUM/52	16,200m³/hr (high)
Max ceiling rake	15°	
Control	Wall control	
Speeds	3	
Body material	ABS	
Blade material	ABS	
Warranty	6 years (4 years in-home + 2 years return to base)	
Weight	COOLUM/48	6.43 kg
	COOLUM/52	6.56 kg

Lamp specifications

Light	20W
Lumens	1500lm, 1500lm, 1600lm
CCT	3000K, 4000K, 5000K
Beam angle	120°
CRI	>80

Product range

Code	SKU	Finish	Fan size
COOLUM/48/LT/WH	18447	White	48" (1220mm)
COOLUM/48/LT/BK	18448	Black	48" (1220mm)
COOLUM/52/LT/WH	18451	White	52" (1320mm)
COOLUM/52/LT/BK	18452	Black	52" (1320mm)

SAFETY INFORMATION

- Fitting must be installed as per AS/NZS3000 regulations.
- Wiring must be completed by a qualified electrician.
- Ensure all electrical connections are secure and that there are no loose strands.
- Do not install this product outdoors or on a damp or newly plastered ceilings.
- An all-pole disconnection switch must be incorporated into the fixed wiring, in accordance with local wiring rules.
- The structure to which the fan is to be mounted must be capable of supporting a weight of 30kg.
- The fan is suitable for indoor and coastal areas provided the fan is fully undercover in a covered and protected area with at least one wall. Fan must be located so that the tip of the blades are no closer than 1.5m to an unprotected area and must be protected from dust, wind moisture and rain.
- The appliance is not to be used by persons (including children) with reduced physical, sensory or mental capabilities, or lack of experience and knowledge, unless they have been given supervision or instruction.
- The replacements of parts of the safety suspension system device shall be performed by the manufacturer, its service agent or suitably qualified persons.

Installation

Read instructions and check you have all the tools and accessories to complete the installation correctly. Isolate the mains power supply before commencing installation. Before commencing, check space for obstructions and ensure adequate clearance for installation (see clearance table).

- Install wall plate and cabling for ceiling fan to desired location in accordance with AS/NZS3000 wiring rules.
- Using the two coach style screws provided or other suitable mounting method, secure the hanging bracket to a structurally rated ceiling joist or suitably rated building element, ensuring it is capable of carrying a load of at least 30kg. Note: the provided screws are for use with wooden structures only. For other structures, the appropriate screws must be used.
- Connect mains cabling to the terminal block as per wiring diagram below and in accordance with AS/NZS 3000 Wiring Rules.
- Insert blades and align the 2 holes on the blade with the 2 holes on the rotating section of fan motor assembly and secure using the 2 blade screws. Ensure all screws are tightened evenly to reduce the chance of warping or unbalancing. Take care not to over tighten the screws, as this can damage the blades.
- Connect the ceiling fan by joining the quick connector cabling attached to the terminal block on the hanging bracket to the corresponding connector on the ceiling fan.
- Lift the fan assembly onto the mounting bracket. Ensure slot (A) of the hanging ball joint is positioned on notch (B) of the mounting bracket to prevent the fan from rotating when in operation.
- Cover mounting bracket with canopy, ensuring all wiring is tucked inside. Secure the canopy using the provided screws ensuring they are not overtightened. For best results leave screws about 4-5mm from mounting bracket and position canopy into key lock slot.

WARNING: If unusual oscillating movement is observed, immediately stop using the ceiling fan and contact the manufacturer, its service agent or suitably qualified persons.

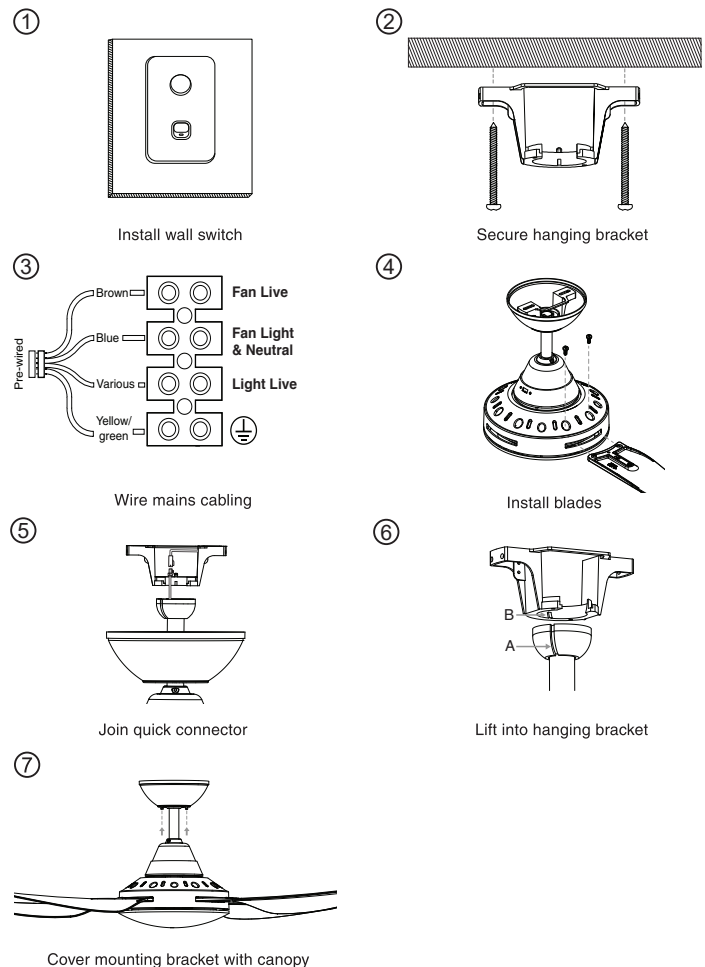

Wiring

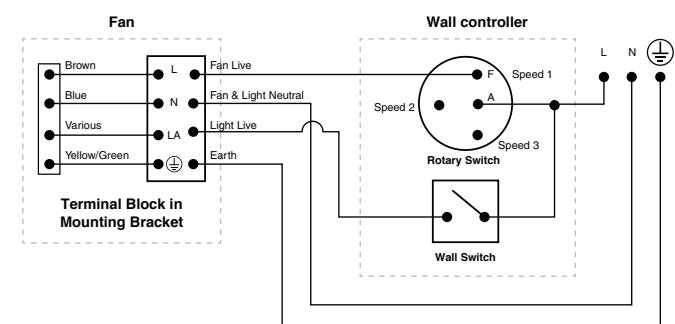

Clearance table

Wall* (from blade tip)	300mm
Floor (from blades)	2.1m (minimum)
Angle	15° max

*or any permanent building element including ceiling and joists

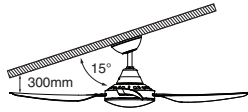
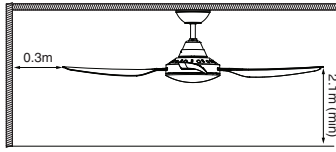

Commissioning

- Run fan in all speeds and directions and check for noise and wobble.
- Check all operational functions.
- Run ceiling fan for 24 hours to bed-in (12 hours in summer mode and 12 hours in winter mode).

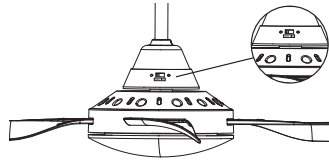

Light control

Selecting the colour temperature: Toggle the light switch ON/OFF, within 3 seconds to select the colour temperature (3000K, 4000K or 5000K). After 3 seconds from last toggle, the light will remain at same colour temperature.

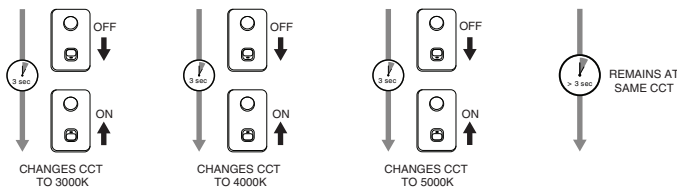

Dimming: The TRI-CCT light kit provided with this fitting is dimmable via a trailing edge dimmer (not included). Please note: dimmers must not be connected to the ceiling fan motor.

Outdoor Operation

This fan is suitable for installation in protected and covered outdoor alfresco areas. Installation location must be protected from dust, wind, rain and salt spray and must include at least one wall. Failure to meet these requirements will void warranty. Ceiling fan must be installed so that the edge of the blades is at least 1.5m away from the edge of the protected area (or eave). Damage and failure through the actions of wind, water and dust ingress or salt spray are not covered by warranty.

Reverse function

Your ceiling fan can operate either in fan (summer) mode or reverse fan (winter) mode. To switch between summer and winter mode, slide the selector switch located on the top of the fan motor body to the required setting.

Summer mode: The reverse switch should be in the "left" (SUMMER) position to rotate the fan in an anticlockwise direction. The airflow will be directed downwards, for cooling in summer.

Winter mode: The reverse switch should be in the "right" (WINTER) position to rotate the fan in a clockwise direction. The airflow will be directed upwards, for energy conservation, ensuring an even temperature throughout your room during winter.

Troubleshooting

Wobble: Ceiling fans can move slightly during operation and does not suggest any problem, however a major wobble should be corrected by use of the balancing kit supplied with your fan after first checking all screws and blade fittings for correct adjustment. Please refer to the instructions supplied with the kit.

Noise: When it is quiet (especially at night) you may hear occasional small noises. Slight power fluctuations and frequency signals superimposed in the electricity for off-peak hot water control, may cause a change in fan motor noise. This is normal. Please note that this is not a product fault - All electric motors are audible to some extent.

Please allow a 24-hour "breaking-in" period, most noises associated with a new fan disappear during this time.

Ripple Control Noise: In parts of Queensland and New South Wales, the electrical authorities may utilise "Ripple Signalling Control" to remotely switch on and off devices such as hot water systems. This signal will vary per geographical area and can become apparent through an intermittent humming noise in an AC ceiling fan motor or a flickering of LED lights at different times of day. We recommend installation of a Ripple Signal Filter - Please consult your licensed electrical contractor to recommend and fit a suitable model for your area.

Standard wear and tear: All ceiling fans are subject to standard wear and tear as the product ages through use. This is normal and will not constitute a product failure under warranty. Defects, wobble and noise caused by impacts, external damage and lack of regular maintenance are excluded from warranty.

Maintenance

- Shut off power before cleaning or maintenance.
- Every 6 months, wipe fan using a soft brush or lint free cloth.
- Do not soak or immerse your ceiling fan in the water or other liquids.
- Ensure that the fan does not come in contact with any organic solvents or cleaners.

Warranty

Atom Air products are distributed in Australia by Evolt Pty Limited ('us', 'our', or 'we'). Our contact information is shown on this manual. This warranty gives you benefits that are additional to other rights and remedies that you may have pursuant to other laws relating to the Atom Air products. Those laws include the Australian Consumer Law and the New Zealand Consumer Law. Evolt's goods come with guarantees that cannot be excluded under the Australian Consumer Law or the New Zealand Consumer Law. You are entitled to a replacement or refund for a major failure and compensation for any other reasonably foreseeable loss or damage. You are also entitled to have the goods repaired or replaced if the goods fail to be of acceptable quality and the failure does not amount to a major failure.

Nothing in this warranty is to be interpreted as excluding, restricting or modifying any law or statute applicable to the supply of Atom Air products which cannot be excluded, restricted or modified by the Australian Consumer Law or the New Zealand Consumer Law (where applicable). If you think your Atom Air product is defective, you can choose to make a claim under:

- The Australian Consumer Law in Australia;
- The New Zealand Consumer Law in New Zealand; and/or
- This warranty, as may be applicable.

Subject to the terms of this contractual warranty, if your Atom Air products are defective, we will (at our election) repair or replace the Atom Air products. Once we make this election (and take the relevant action), we will have honoured our obligations under this contractual warranty. Our total liability under this warranty is limited to the cost of repair or replacement of the defective product (at our election). We otherwise exclude all liability in relation to the product to the fullest extent permitted by law (noting our comments above regarding the Australian Consumer Law and any other rights or remedies you may have).

Evolt warrants that it will remedy premature product failure and defects caused by faulty materials or workmanship in Atom Air products as follows:

Product Type	Warranty	Remedy
Commercial Use	1 MONTH (return to base)	Atom Air products labelled 'return to base' are remedied by Evolt at our own premises (or agent's premises).
Domestic use ceiling fans (motor, light and DC remote control)	6 YEARS (including 4 Years in-home + 2 years return to base)	This means that you are responsible for delivering the Atom Product to us for repair, replacement or refund, and collecting the Atom Air product from us once it has been repaired or replaced.
Domestic use remote controls (sold separately)	3 YEARS (return to base)	Atom Air products labelled 'in-home' are remedied by Evolt at the site which the Atom Air Product has been supplied or installed.
Software or consumables (such as globes and heat lamps)	1 YEAR (return to base)	

All warranty periods apply from date of purchase. Date of purchase means the date that you purchased the Atom Air product from an Evolt authorised wholesaler or retailer, unless marked otherwise.

For this warranty to apply, you must:

- Have purchased the Atom Air product from Evolt or our authorised distributors in Australia or New Zealand;
 - Follow the manufacturer's instructions applicable to the Atom Air products;
 - Follow the Industry Standards for installation and usage applicable to the Atom Air products (if any);
 - Follow any other written or verbal instructions for installation, operation, care, repair and maintenance of the Atom Air products. Those directions may be given by Evolt, supplied with the Atom Air products, printed on the labels, packaging or operation manuals, published on the Evolt website or otherwise published by Evolt from time to time; and
- Follow the claims procedure for making a warranty claim as outlined in this document.

For our full warranty terms and conditions please visit our website at www.atomlighting.com.au/warranty/.

Within 7 days of any defect arising (or the day that you should have reasonably become aware of the defect), You must notify Evolt of the defect in writing:

What must be included in the warranty claim

- proof of purchase (if available)
- date and place of purchase
- the item number / code of the returned product
- the number of items claimed
- the reason for the claim and written description of the defect (including photographs where reasonably possible)
- any information provided by the customer your written assurance that the Atom Air products have not been:
 - incorrectly assembled or installed;
 - incorrectly operated or used or maintained;
 - incorrectly repaired or modified;
 - exposed to abnormal conditions; or damaged by you (due to negligence or otherwise) request for labour allowance rates (if applicable)

To lodge a warranty claim, please visit our website at www.atomlighting.com.au/warranty/. Alternatively you can make a claim through Evolt at email address at sales@evolt.com.au or mailing address Unit 5, 105A Vanessa Street, Kingsgrove NSW 2208, Australia (telephone 1300 438 658). Once we receive your warranty claim, we will contact you within 2 working days and confirm whether the Atom Air product is 'return to base' or 'onsite'.

This warranty does not apply to loss or damage caused by wear and tear, misuse, incorrect installation or operation, failure to clean and maintain, incorrect voltage or non-authorised electrical connections, adverse external conditions (such as power surges and dips, acts of God, exposure to heat, corrosion, insect or vermin infestation), use of non-authorised or defective parts or globes, or to items that have been repaired than by a person other than us or a repairer



Visit our website for more information

V1.0

Atom is a registered brand of Evolt Pty Limited.

IMPORTANT: THIS PRODUCT MUST BE INSTALLED BY A LICENSED ELECTRICIAN.

Due to changes in industry standards and Evolt's policy of continual product development, product specifications are subject to change without notice.

Images are for illustrative purposes only.

For further information please call Evolt's head office on 1300 4EVOULT (438 658).

Evolt Pty Limited PO BOX 271 KINGSGROVE NSW 1480

ABN 83 112 123 529

www.evolt.com.au

evolt