

SolarEdge Home Battery 48V

Used with SolarEdge inverters

Quick Installation and Operation Guide
for Europe



Unpacking and mounting video



Wiring video



Battery Installation Manual



Battery Warranty



Emergency Response guide, including emergency phone numbers



Safety Datasheet



Battery Datasheet



Transportation Guide



Support Contact Information

In case of any technical issues with SolarEdge products, please contact us at: <https://www.solaredge.com/service/support>

© SolarEdge Technologies, Ltd.
All rights reserved.
V1.1 May 2024
Subject to change without notice.

What's in the Package

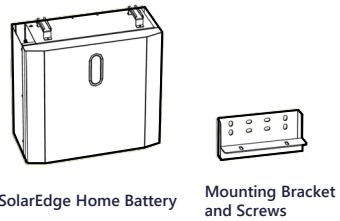

Ordered Separately

	Width	Height	Depth
Battery module	540mm	500mm	240mm
Tower cover	540mm	120mm	240mm
Floor stand	535mm	50mm	210mm

Available Cables

	Battery to Battery	Tower to Tower	Battery to inverter
DC cables	57cm	260 cm	260 cm
Ground cable	55cm	170 cm	260 cm
Communication cable	57cm	170 cm	260 cm

Required Personnel



Min 2 qualified installers



Tools and Materials

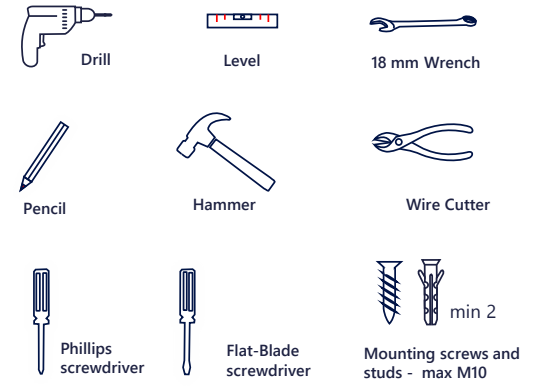

WARNING! This symbol denotes a hazard. It calls attention to a procedure that if not correctly performed or adhered to could result in injury or loss of life. Do not proceed beyond a warning note until the indicated conditions are fully understood and met.

WARNING! Before installing or operating the SolarEdge Home Battery, read the Safety and Handling instructions at the back of this page.

1 Turning off the Battery Power

WARNING! Make sure that the circuit breakers of the battery are in the OFF position and all LEDs are turned off.

3 Floor Stand Positioning and Leveling

WARNING! Mount the battery on a stable surface

NOTE: Before installing batteries on top of each other, checked that the max tilt of the wall is 1.5%

2 Planning and Considerations

WARNING! Connect no more than 5 batteries per inverter. Use no more than 2 battery towers. A battery tower should have no more than 4 batteries.

4 Installing the Mounting Bracket

NOTE: Use a minimum of two wall screws to install the bracket. Use additional screws to reinforce installation according to wall condition.

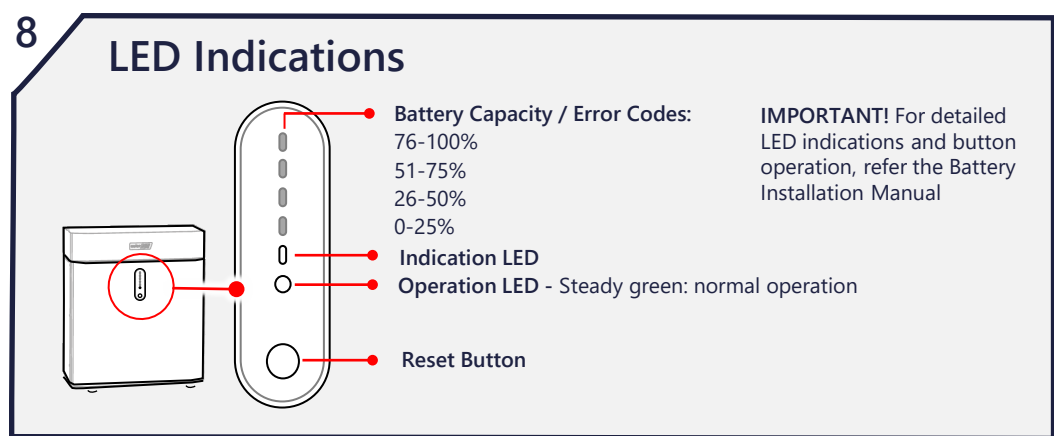
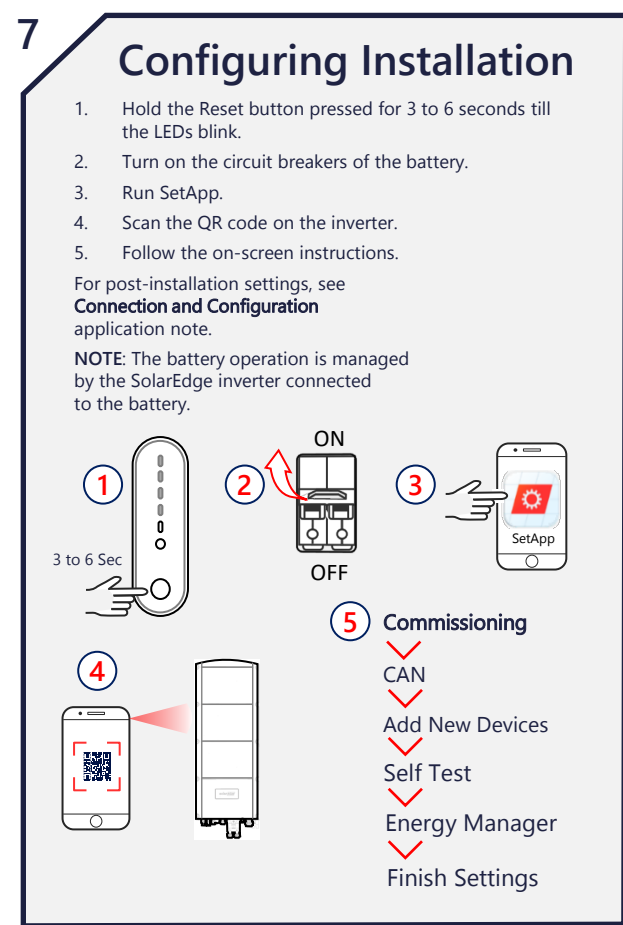
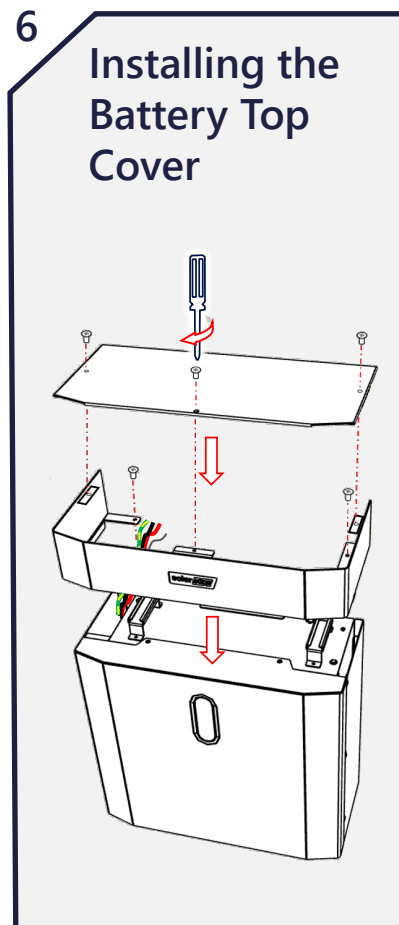
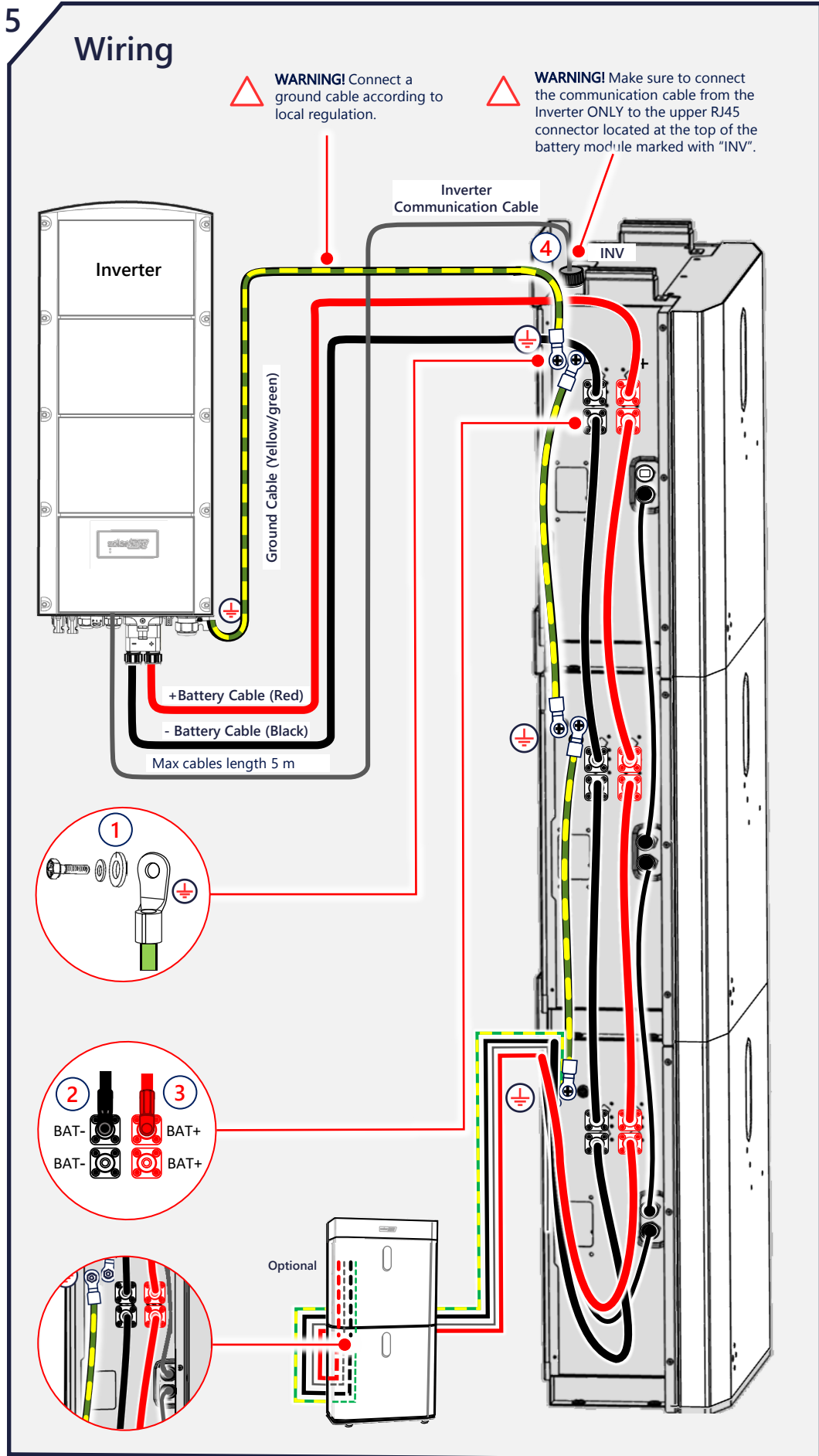

Handling Cautions

- The Battery contains rechargeable lithium-ion cells that are potentially hazardous and can present a serious fire hazard, injury and/or property damage if damaged, defective or improperly used.
- In case of an electrolyte leak from the Battery, avoid contact with electrolyte and follow the instructions in the *SolarEdge Home Battery – Emergency Response Guide*.
- Changes or modifications not expressly approved by SolarEdge for compliance may void the user's authority to operate the Battery.
- Use the Battery only as directed in this document.
- Do not use the Battery if it is defective, appears cracked, broken, or otherwise damaged, or fails to operate.
- The Battery and its components are not user-serviceable.
- Do not attempt to open, disassemble, repair, tamper with, or modify the Battery. The Battery cells are not replaceable.
- Do not operate the Battery at ambient temperatures of above 50°C/122°F or below -10°C/14°F. Operating the Battery in temperatures outside the specified range might cause damage to the Battery.
- Do not expose the Battery or its components to direct flame.
- Do not store or use flammable liquids or gasses in the vicinity of the Battery.
- Do not place any combustible items in the vicinity of the Battery.
- If the Battery catches fire, or if fire breaks out near the Battery, call the fire department immediately and follow the instructions in the *SolarEdge Home Battery – Emergency Response Guide*.
- The Battery is prone to re-ignition after extinguishing. Use caution and follow the emergency response instructions.
- Do not immerse the Battery or its components in water or other fluids.
- Charge and discharge voltage: 44.8-56.5 Vdc.
- Do not use solvents to clean the Battery or expose the Battery to flammable or harsh chemicals or vapors.
- Do not use fluids, parts, or accessories other than those specified in this guide, including use of non-genuine SolarEdge parts or accessories, or parts or accessories not purchased directly from SolarEdge or a SolarEdge certified party.
- After the installation, do not place the Battery in storage conditions for more than one (1) month, or permit the power feed to the Battery to be discontinued for more than one (1) month.
- Do not paint any part of the Battery, including any internal or external components such as the exterior shell or casing.
- Ensure that snow does not accumulate around the Battery.
- A non-functioning Battery must be handled with caution. The Battery state of charge and risk of venting may be unknown. Contact SolarEdge for assistance.
- Do not attempt to remove or transport a damaged or non-functioning battery. Contact SolarEdge or your SolarEdge certified installer for support.
- This symbol  on the product means: Do not dispose of this product with general household waste. Consult your local regulations for proper disposal instructions.

SAFETY AND HANDLING INSTRUCTIONS

Read this entire document before installing or operating the SolarEdge Home Battery (referred to as the "Battery"). Failure to do so or to follow any of the instructions or warnings in this document can result in electrical shock, serious injury, or death, or may damage the Battery and other property. Do not discard this document! After installation, keep it adjacent to the Battery for future reference!

Installation

- Install the battery according to national and local codes and standards and in locations compliant with local building codes and standards.
- The Battery installation must be carried out only by qualified electricians who have been trained in handling low voltage electricity works.
- The Battery is heavy. Adhere to local regulations for material handling and heavy lifting, when installing heavy equipment.
- Do not install the Battery in habitable spaces, including sleeping rooms.
- Make sure the mounting surface can sustain the total weight of the Battery and mounting bracket.
- Do not install the Battery, if it has been dropped, crushed, or has signs of physical damage.
- When the Battery is installed in a residential environment, fire detection and protection equipment must be installed in accordance with local building and fire codes.
- Do not install the Battery near heating equipment, ignition sources, or open flames.
- Install the Battery only on non-combustible surfaces and under non-combustible ceilings, overhangs, or eaves.
- Do not install the Battery in proximity to gas meters, valves, regulators, lines, or gas appliances. Follow local codes. However, 2m / 6ft or more spacing is highly recommended. A failing battery may ignite flammable gasses resulting in property damage, serious injury, or death.
- Avoid installing the Battery in direct sunlight.
- Install the Battery in a location protected from flooding.
- Do not install the Battery in the vicinity of water sources, including downspouts, sprinklers, or faucets.
- When installing the Battery in a garage or near vehicles, keep it out of the driving path. If possible, install the Battery on a side wall and/or above the height of vehicle bumpers.
- Before beginning the wiring, ensure that the Battery is switched off. Also, make sure that the DC safety switch of all inverters in the PV system is turned off.