



 COOLON

ZEENO

150W/240W LED High Bay

Robust industrial LED high bay with optical variations for different heights

The Zeeno is a compact and powerful high bay that has been engineered to withstand electrical surges that typically damage conventional high bays.

Available in 150W or 240W in combination with a range of low glare optics to suit a variety of applications and various mounting heights.

Designed for use in:

- Industrial Facilities
- Maintenance Workshops
- Mills and Factories
- Warehouses and Cold Stores
- Stadiums / Sports Halls
- Workshops
- Undercover Flotation Tanks
- Undercover Stockpiles
- Public Spaces
- Retail Stores
- Agriculture



Engineered to perfection

High intensity light output. Over 135 lm/W efficiency.
Low power consumption. Long life endurance. Zeeno is the ideal industrial high bay light.

Fast payback, instant results

Zeeno delivers instant results without breaking the bank. It's high performance to cost ratio, make a great case for a very fast payback on your investment.



COOL SURFACE TEMPERATURE

Coolon's industrial LED fittings have a much lower surface temperature than traditional HID equivalents which prevents dirt from baking onto the luminaire. This allows for easier cleaning and prolongs the lifespan of the luminaire.



NO FLICKERING

LED luminaires run on constant low voltage DC power and do not produce any visible stroboscopic effects. This reduces strain on the eyes and significantly improves safety in areas where moving machinery is present.



UNRESTRICTED BURNING POSITION

Coolon's LED luminaires can be positioned and oriented in any direction without affecting the lifespan of the product. This provides greater flexibility when it comes to aiming angles and orientation.



3 YEARS FACTORY WARRANTY

Coolon luminaires are covered by a comprehensive manufacturer's warranty that covers a range of possible defects and performance parameters throughout the duration of the warranty period.



INSTANT ON/OFF

LEDs do not have a warm up period. Instant on to 100% output translates to no downtime, improved safety and the ability to utilize sensor switching to significantly reduce energy usage.



LONG USEFUL OPERATING LIFE

Currently available specification from world's most reputable LEDs manufacturers states 50,000 hours of continuous operation at the rated current within the operating temperature range to 70% residual light output.



LOW SUSCEPTIBILITY TO VIBRATION

The Emergency Pack is designed to handle continuous exposure to vibration. Designed specifically to be mounted away from the luminaire to minimize the weight of the luminaire and effects of mechanical shock and vibration.



DESIGNED AND BUILT FOR AUSTRALIAN CONDITIONS

Engineered to perfection, using only the highest quality components and highly skilled labour, each luminaire is assembled and thoroughly tested to ensure that it exceeds the highest standards.

DIMENSIONS

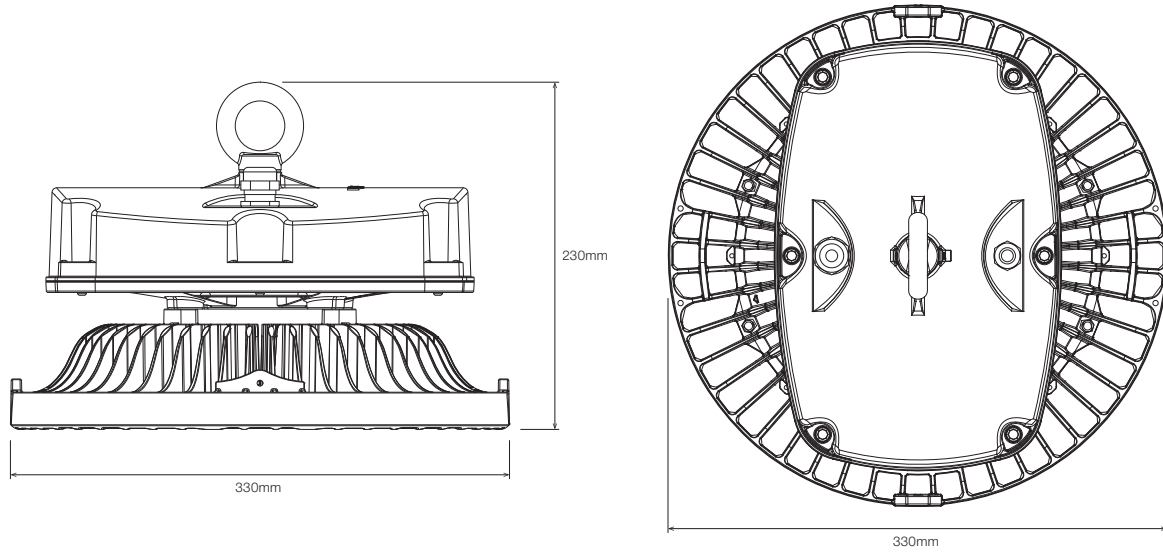

TECHNICAL SPECIFICATIONS

Product	Zeeno LED High Bay	
Model	ZHB-150	ZHB-240
Optical Characteristics		
Luminous Flux	24,768 – 25,146 lm	32,662 – 33,312 lm
CCT	NWT	
CRI	>70	
Electrical Characteristics (Luminaire)		
Power Consumption	154W Typical	245W Typical
Nominal Voltage	230VAC	
Voltage Range	200 - 440VAC / 285-550VDC	
Frequency Range	50 – 60Hz	
Power Factor	≥0.98 / 230VAC	
Leakage Current	<0.75mA / 480VAC	
Cable Type	Standard 3 Core Flex with Molded 3 Pin AU Plug	
Cable Length	1.5m	

Environmental		
IP Rating	IP65	
Impact Rating	IK08	
Salt Spray Tested	Yes	
Operating Temp. Range	-20 to +50°C	
Thermal Management Type	Active/Continuous	
Expected Lifespan	50,000 Hours to 70% Brightness	
Material Composition (Body)	ADC12 Aluminium Alloy	
Material Composition (Optics)	Polycarbonate	
Weight/Packaging		
	150W	240W
Luminaire Dimensions	L 330mm x W 330mm x H 230mm	
Luminaire Weight	6.3kg	6.5kg
Packaging Dimensions	L 400mm x W 400mm x D 290mm	
Packaged Weight	7.5kg	7.7kg

Warranty		
Warranty	3 years warranty as standard 5 years extended warranty optional	

¹ Reading taken while test unit operating in steady state. Ambient temperature during testing is typically 25°C. Individual unit behaviour may differ due to electronic component tolerance and ambient conditions. Product parameters and application suitability shall be checked by the user prior to commissioning.

COLOUR TEMPERATURES



All colour temperatures are indicative. Some variation can occur.

ILLUMINANCE AT DISTANCE

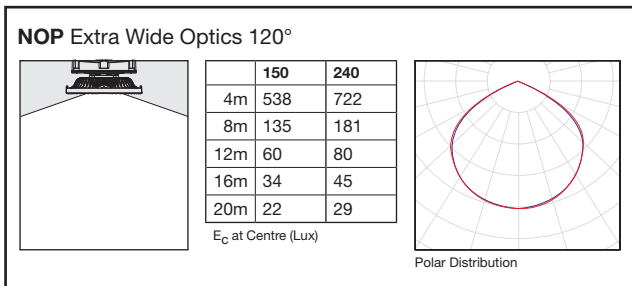
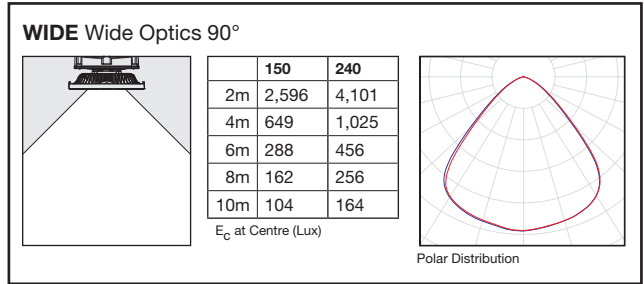
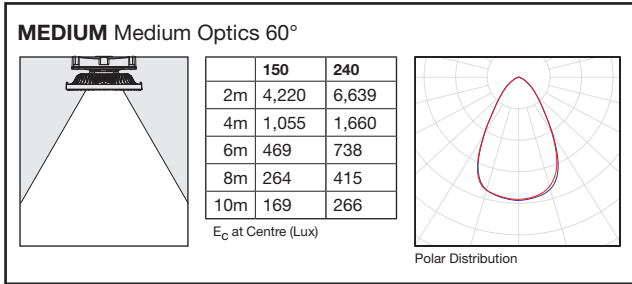

ORDERING EXAMPLE

ZHB - 240 - NWT - MEDIUM - MP

PRODUCT TYPE COLOUR TEMPERATURE BEAM SUPPLY OPTION

PRODUCT	TYPE	COLOUR TEMPERATURE	BEAM	SUPPLY OPTION
ZHB Zeeno High Bay	150 150W	NWT Neutral White	MEDIUM Medium Optics	MP Mains Powered
	240 240W		WIDE Wide Optics	
			NOP Extra Wide Optics	